

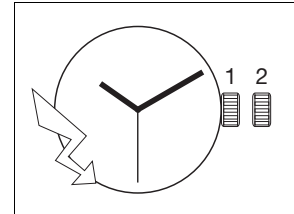

8 3/4''' ETA F04.101

CT F04101 ESI 575491 03 06.08.2014

8 3/4''' Ø 19,40 mm



Movement height	Altura sobre máquina	Altezza sopra movimento	2,50 mm
Height on battery	Altura sobre pila	Altezza sopra pila	No. 364: 2,65 mm No. 377: 3,10 mm
Number of jewels	Número de piedras	Numero di pietre	3
Frequency	Frecuencia	Frequenza	32'768 Hz

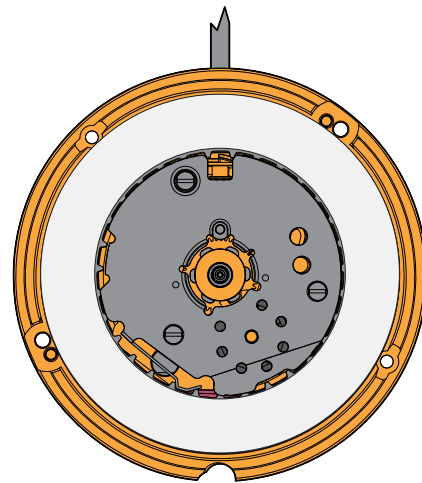
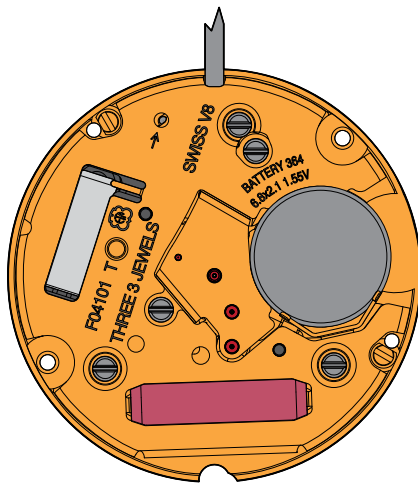

The repair and reconditioning work must only be performed by properly trained personnel.  
Las tareas de reparación y revisión sólo deben ser llevadas a cabo por personal debidamente formado.  
I lavori di riparazione e di revisione devono essere eseguiti esclusivamente da personale adeguatamente formato.



## General information



**Before** starting work, please study this "Technical communication" carefully.



Eye protection is obligatory for all operations / work on the movement!



ETA SA disclaims any liability in case of damage arising from failure to observe this "Technical communication".

## Environmental protection requirements



**The legal provisions relating to waste handling and disposal must be observed in all operations / work on the movement!**

In particular, lubricating and cleaning products harmful to the environment must be disposed of in accordance with the rules!



**Substances prone to cause water pollution** must be stored, transported, collected and disposed of in appropriate vessels.

**Under no circumstances must they pollute the soil or be poured into sewage systems!**

## Explanation of symbols



**Caution! Risk of material damage!**

Below are some obligatory instructions for preventing any material damage!



Below is some advice for use and important information.

## Información general



Esta "Comunicación técnica" deberá estudiarse muy bien **antes** de comenzar los trabajos.



Es obligatorio utilizar protección ocular para todos los trabajos en y con el reloj.



ETA SA no se hace responsable de los daños provocados como consecuencia de la inobservancia de esta "Comunicación técnica".

## Normas de protección medioambiental



**Deberá cumplirse la normativa legal relativa al reciclaje y la eliminación correctos de los residuos en todos los trabajos en y con el reloj.**

En especial, deberán eliminarse correctamente los productos lubricantes y de limpieza peligrosos para el medio ambiente.



**Las sustancias contaminantes del agua** deben recogerse, almacenarse, transportarse y eliminarse en recipientes adecuados.

**En ningún caso se permitirá que contaminen el suelo o que lleguen a la canalización.**

## Significado de los símbolos



**Atención Peligro de daños materiales**

Instrucciones que deberán respetarse necesariamente para evitar daños materiales.



Consejos de aplicación e información importantes.

## Informazioni generali



Questa "Comunicazione Tecnica" deve essere studiata attentamente **prima** dell'inizio dei lavori.



Per tutti i lavori su e con il movimento dell'orologio è obbligatorio proteggere gli occhi!



ETA SA declina qualunque responsabilità per eventuali danni causati dalla mancata osservanza della presente "Comunicazione tecnica".

## Disposizioni relative alla protezione ambientale



**Per tutti i lavori su e con il movimento dell'orologio si dovranno rispettare le disposizioni di legge relative al corretto riciclaggio e smaltimento dei rifiuti!**

In particolare si dovrà provvedere al corretto smaltimento di lubrificanti e detergenti nocivi per l'ambiente!



**Le sostanze inquinanti per l'acqua** devono essere conservate, trasportate, raccolte e smaltite in contenitori adatti.

**Queste non devono inquinare il terreno o arrivare nelle canalizzazioni!**

## Spiegazione dei simboli



**Attenzione! Pericolo di danni materiali!**

Seguono importanti indicazioni che devono essere tassativamente rispettate per evitare danni materiali!



Seguono consigli per l'uso e informazioni importanti.

List of components - Lista de piezas - Lista fornitori

Pos	No	No CS	Article number Número de artículo Numero articolo		List of components	Lista de piezas	Lista fornitori
1	100	10.020.07	7613226008465		Main plate, jewelled	Platina, empedrado	Piastra, con pietre
1-1	144	10.300.00	Var	2x	Dial fastener	Sujetador de cuadrante	Ferma-quadrante
2	407	31.121.00	7613226042834		Sliding pinion	Piñón corredizo	Pignone scorrevole
3	405	51.020.21	Var		Handsetting stem	Tija de puesta en hora	Albero di messa all'ora
4	443/1	51.080.06	7613226050365		Setting lever, assembled	Tirete, ajustado	Tiretto, montato
5	435	51.050.00	7613226005228		Yoke	Báscula de piñón corredizo	Bascula del pignone scorrevole
6	445	51.090.00	7613226133495		Setting lever jumper	Muelle flexible de tirete	Scatto del tiretto
7	4021	20.582.00	7613226013728		Stator	Estator	Statore
8	4022	80.102.06	7613226015388		Electronic module distance piece, assembled	Tirante del módulo electrónico, montado	Spessore del modulo elettronico, montato
9	4402	20.763.00	7613226019881		Bridle -	Brida -	Brida -
10	-	81.171.00	7613226003460		Washer	Rodaja	Rondella
11	4211	20.580.00	7613226022812		Rotor	Rotor	Rotore
12	203	30.012.00	7613226024922		Intermediate wheel	Rueda intermedia	Ruota intermedia
13	210	30.025.00	7613226030107		Third wheel	Rueda primera	Ruota mediana
14	227	30.027.00	Var		Second wheel	Rueda de segundos	Ruota dei secondi
15	110	10.048.07	7613226143753		Train wheel bridge, jewelled	Puente de rodaje, empedrado	Ponte del ruotismo, con pietre
16	4046	20.651.00	7613226025097		Battery insulator	Aislador de pila	Isolatore della pila
17	4000	10.513.00	7613226016507		Electronic module	Módulo electrónico	Modulo elettronico
18	4407	20.764.00	7613226043275		Bridle +	Brida +	Brida +
19	4038	20.584.00	7613226144040		Electronic module cover	Cubre-módulo electrónico	Copri-modulo elettronico
20	242	31.083.00	Var		Cannon pinion with driving wheel	Cañón con rueda de arrastre	Pignone calzante con ruota conduttrice
21	260	31.041.00	7613226017115		Minute wheel	Rueda de minutería	Ruota della minuteria
22	462	10.062.00	7613226037250		Minute train bridge	Puente del rodaje de minutería	Ponte del ruotismo di minuteria
23	255/1	31.046.06	Var		Hour wheel, assembled	Rueda de horas, ajustada	Ruota delle ore, montata
24	2557/1	91.440.22	7613226073340		Date indicator, raw	Indicador de fecha, bruto	Indicatore della data, bruto
25	2595	13.111.00	Var		Maintaining plate	Placa de sujeción	Placca di guardia
26	4929	20.570.00	Var		Battery	Pila	Pila
27	4412	10.601.00	7613226017276		Battery limiting spring	Muelle de limitación de pila	Molla di limitazione della pila
900	-	88.502.00	7613226004085	2x 3x	Cylindrical head screw - Pos. 15: Screw for train wheel bridge - Pos. 19: Screw for electronic module cover	Tornillo de cabeza cilíndrica - Pos. 15: Tornillo del puente de rodaje - Pos. 19: Tornillo del cubre-módulo electrónico	Vite a testa cilindrica - Pos. 15: Vite del ponte del ruotismo - Pos. 19: Vite del copri-modulo elettronico
901	-	88.542.00	7613226021693	1x 3x	Countersunk head screw - Pos. 22: Screw for minute train bridge - Pos. 25: Screw for maintaining plate	Tornillo de cabeza cónica - Pos. 22: Tornillo del puente de rodaje de minutería - Pos. 25: Tornillo de placa de sujeción	Vite a testa conica - Pos. 22: Vite del ponte del ruotismo di minuteria - Pos. 25: Vite della placca di guardia
902	-	88.582.00	7613226031937	1x	Shouldered flat head screw - Pos. 6: Screw for setting lever jumper	Tornillo de asiento, cabeza chata - Pos. 6: Tornillo de muelle flexible de tirete	Vite con piano di appoggio, testa piana - Pos. 6: Vite del scatto del tiretto
			Var		Variante	Variante	Variant

**Interchangeability and variants can be found on the ETA ONLINE SHOP (EOS):**

[www.eta.ch](http://www.eta.ch)  
→ Support Center  
→ Support Center Portal

**La intercambiabilidad y las variantes se encuentran en ETA ONLINE SHOP (EOS):**

[www.eta.ch](http://www.eta.ch)  
→ Support Center  
→ Support Center Portal

**L'intercambiabilità e le varianti si trovano sul ETA ONLINE SHOP (EOS):**

[www.eta.ch](http://www.eta.ch)  
→ Support Center  
→ Support Center Portal

Materials - Fornituras - Forniture

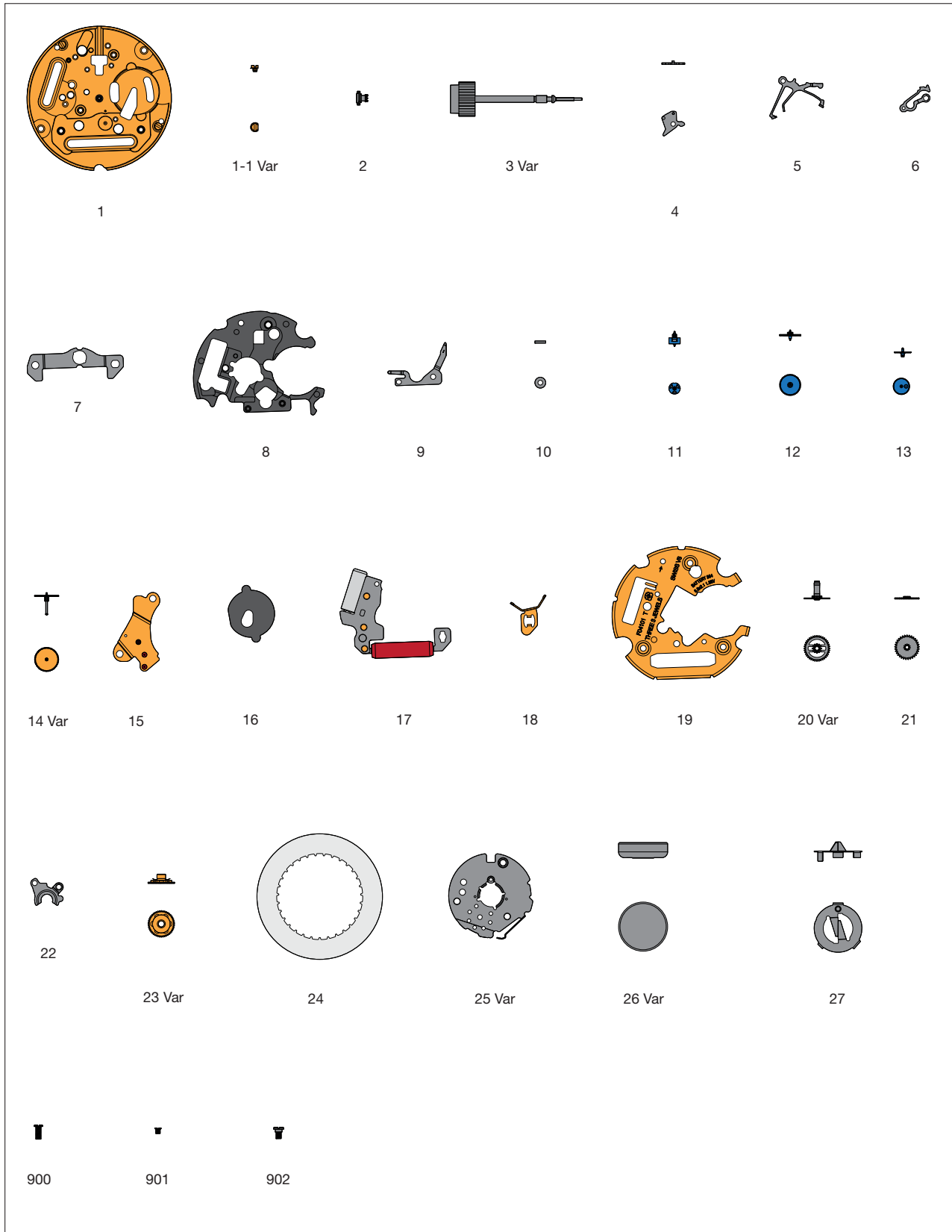

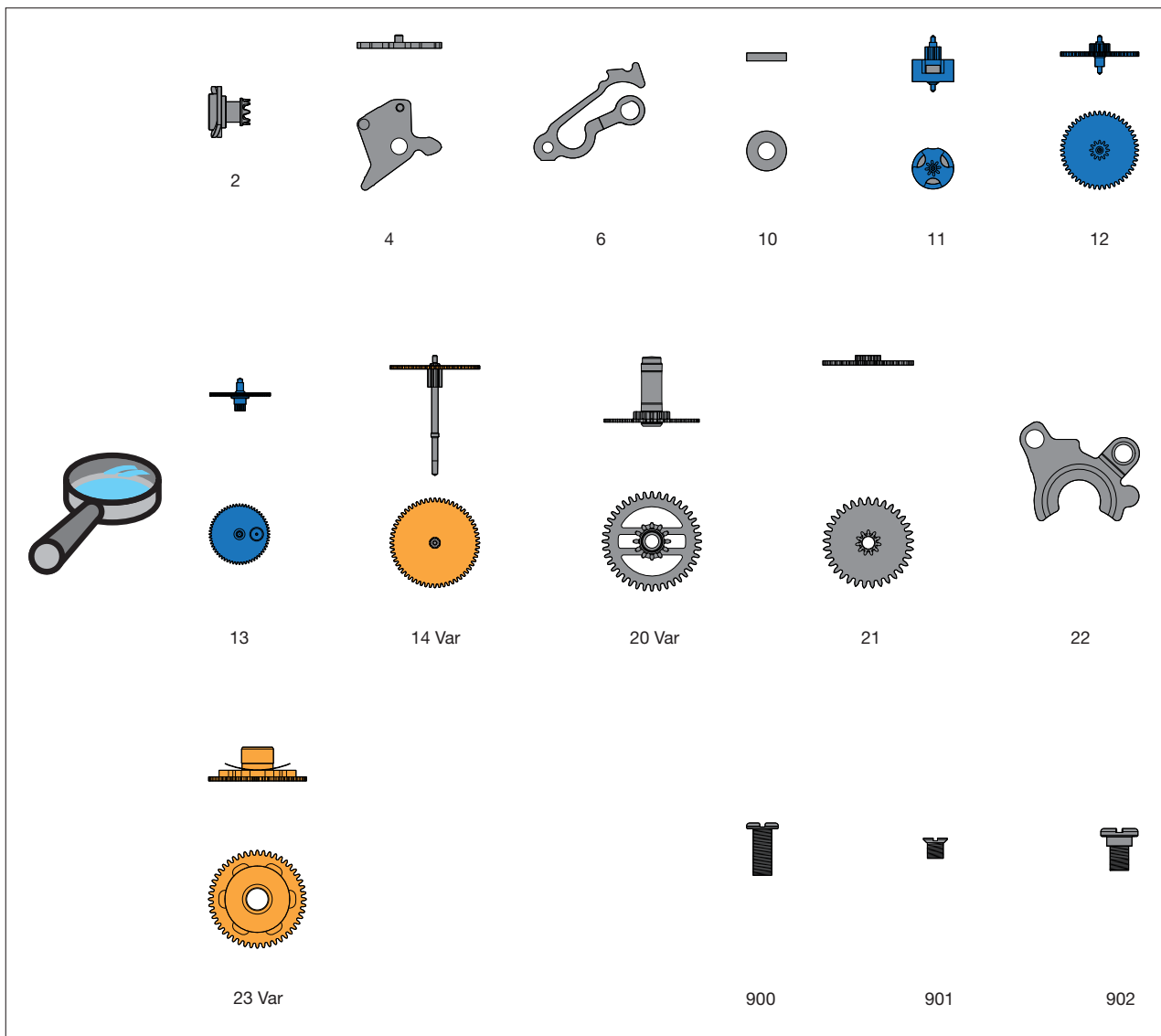

Order of assembly - Orden del montaje - Ordine dell'assemblaggio:  
 Basic movement - Basiswerk - Basic movement

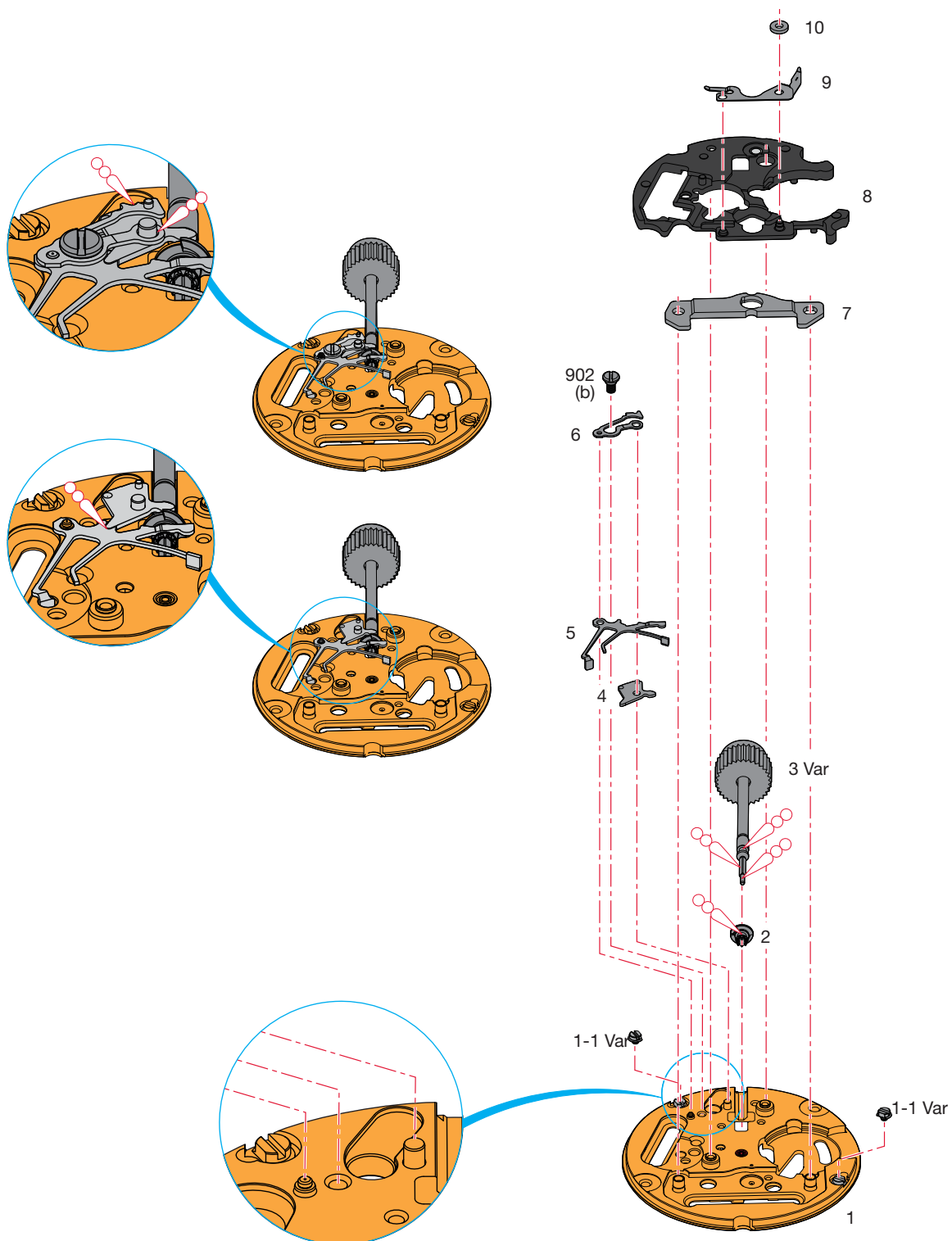

**Assembling of the basic movement**

(Parts listed in order of assembly)

**Montaje de la máquina de base**

(Lista de forniture por orden de ensamblado)

**Montaggio del movimento di base**

(Elenco delle forniture in ordine di montaggio)

1	5	8
2	6	9
3 Var	902 (1x)	10
4	7	

**Lubrication - Lubricación - Lubrificazione**

Thick oil or grease  
Aceite espeso o grasa  
Olio denso o grasso

**Moebius**  
**HP-1300**  
or / ó / o  
**Moebius D5**

**M<sub>L</sub> Minimum torque for loosening**

**M<sub>L</sub> Par mínimo para desatornillar**

**M<sub>L</sub> Coppia minima per svitare**

(b) 0,7 Ncm

Order of assembly - Orden del montaje - Ordine dell'assemblaggio:  
 Wheel train - Rodaje - Ruotismo

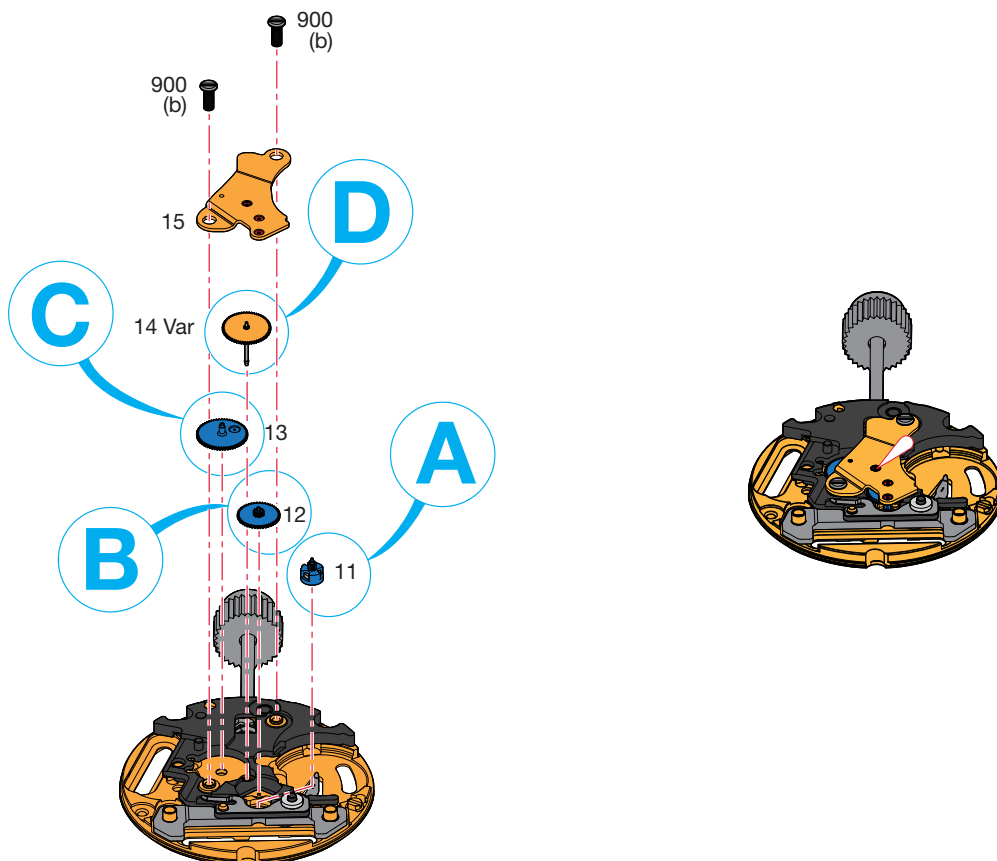
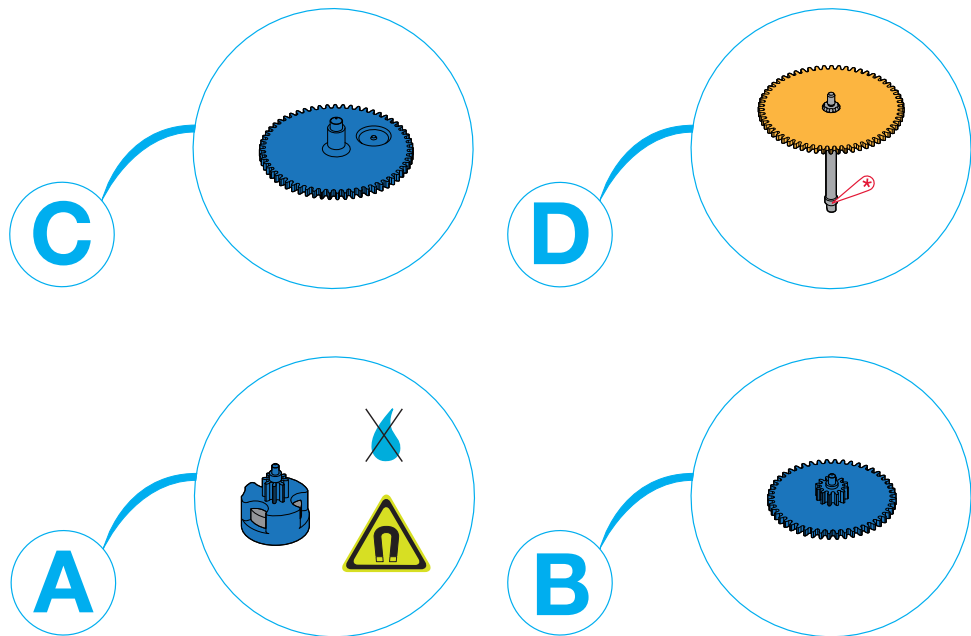



### Assembling of the wheel train

(Parts listed in order of assembly)

### Montaje del rodaje

(Lista de fornitureas por orden de ensamblado)

### Montaggio del ruotismo

(Elenco delle forniture in ordine di montaggio)

11	13	15
12	14 Var	900 (2x)

### Lubrication - Lubricación - Lubrificazione

 Fine oil **Moebius 9014**  
Aceite fino or / ó / o  
Olio fluido **Moebius 9034**

 Very small quantity **Moebius 9014**  
Cantidad muy pequeña or / ó / o  
Piccolissima quantità **Moebius 9034**

 Do not wash. If the part is very dirty or rusty, it should be exchanged for an original part which is lubricated and delivered by ETA SA.

Na lavar. Si la pieza está muy sucia o herrumbrosa, cambiar por una forniturea de origen entregada lubricada por ETA SA.

Non lavare. Se il pezzo è molto sporco arrugginito, sostituire con una forniturea di origine fornita lubrificata da ETA SA.

### M<sub>L</sub> Minimum torque for loosening

### M<sub>L</sub> Par mínimo para desatornillar

### M<sub>L</sub> Coppia minima per svitare

(b) 0,7 Ncm



Before assembly, check that no metal filings or impurities have remained on the magnet.

Antes del montaje, compruebe que no hayan quedado limaduras metálicas o impurezas en el imán.

Prima del montaggio, assicurarsi che non siano rimasti trucioli metallici o altre impurità sur magnete.

Order of assembly - Orden del montaje - Ordine dell'assemblaggio:  
Electronic module - Módulo electrónico - Modulo elettronico

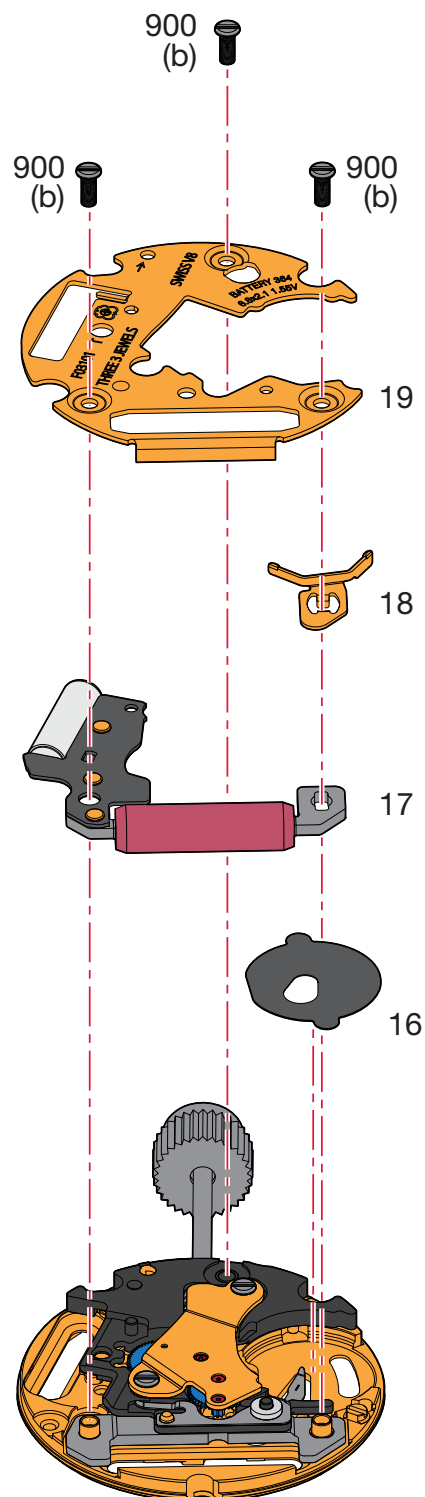

**Assembling of the electronic module**

(Parts listed in order of assembly)

**Montaje del módulo electrónico**

(Lista de fornitureas por orden de ensamblado)

**Montaggio del modulo elettronico**

(Elenco delle forniture in ordine di montaggio)

16	18	900 (3x)
17	19	

**M<sub>L</sub> Minimum torque for loosening****M<sub>L</sub> Par mínimo para desatornillar****M<sub>L</sub> Coppia minima per svitare**

(b) 0,7 Ncm

Order of assembly - Orden del montaje - Ordine dell'assemblaggio:  
Calendar mechanism - Mecanismo de calendario - Meccanismo del calendario

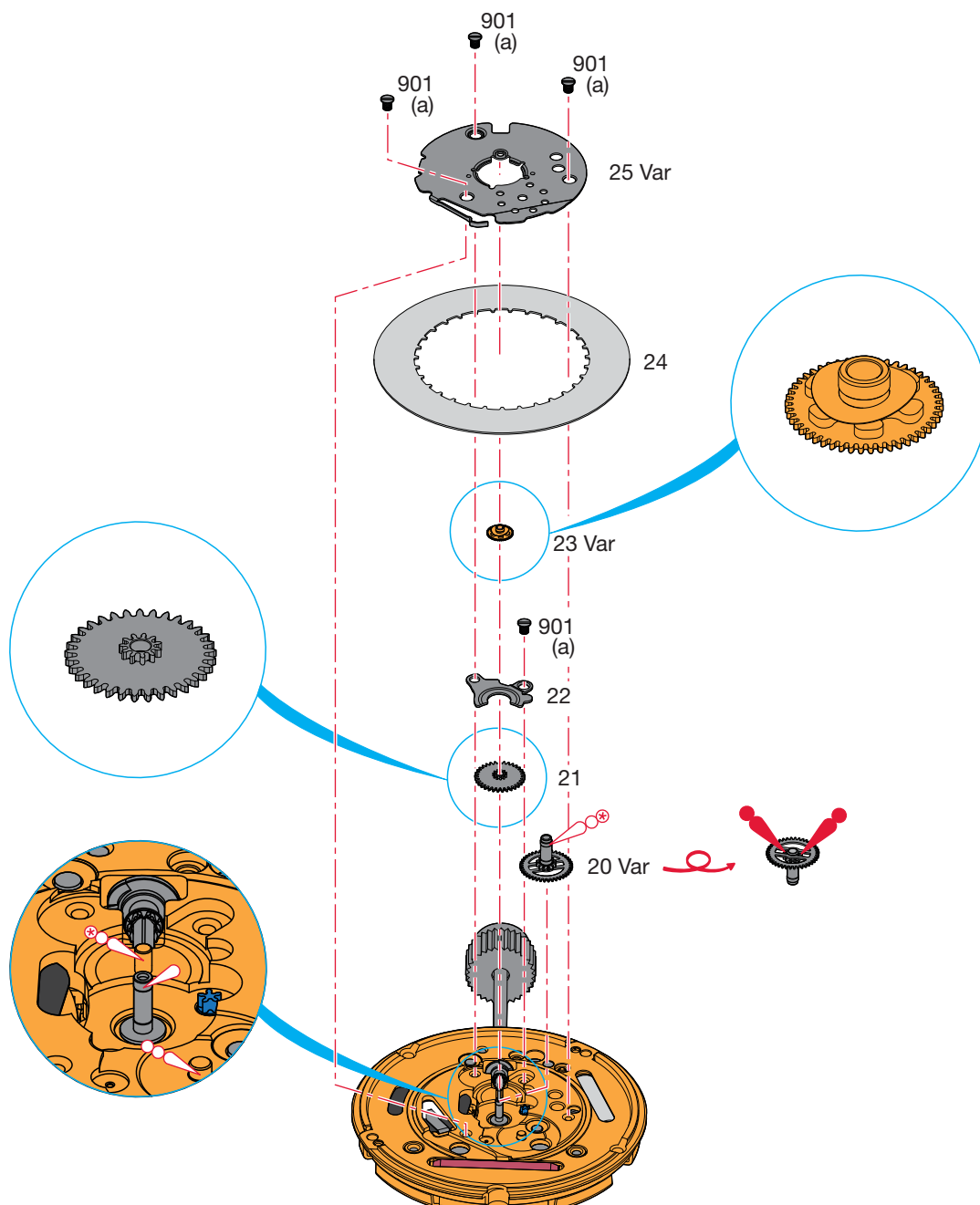

**Assembling of the calendar mechanism**

(Parts listed in order of assembly)

**Montaje del mecanismo de calendario**

(Lista de fornitureas por orden de ensamblado)

**Montaggio del meccanismo del calendario**

(Elenco delle forniture in ordine di montaggio)

20 Var	901 (1x)	25 Var
21	23 Var	901 (3x)
22	24	

**Lubrication - Lubricación - Lubrificazione**

 Fine oil  
Aceite fino  
Olio fluido

**Moebius 9014**

or / ó / o

**Moebius 9034**

 Very small quantity  
Cantidad muy pequeña  
Piccolissima quantità

**Moebius****HP-1300**

or / ó / o

**Moebius D5**

 Grease  
Grasa  
Grasso

**Moebius 9501**

or / ó / o

**Jismaa 124**

 Thick oil or grease  
Aceite espeso o grasa  
Olio denso o grasso

**Moebius****HP-1300**

or / ó / o

**Moebius D5****M<sub>L</sub> Minimum torque for loosening****M<sub>L</sub> Par mínimo para desatornillar****M<sub>L</sub> Coppia minima per svitare**

(a) 0,6 Ncm

Order of assembly - Orden del montaje - Ordine dell'assemblaggio:  
Battery - Pila - Pila

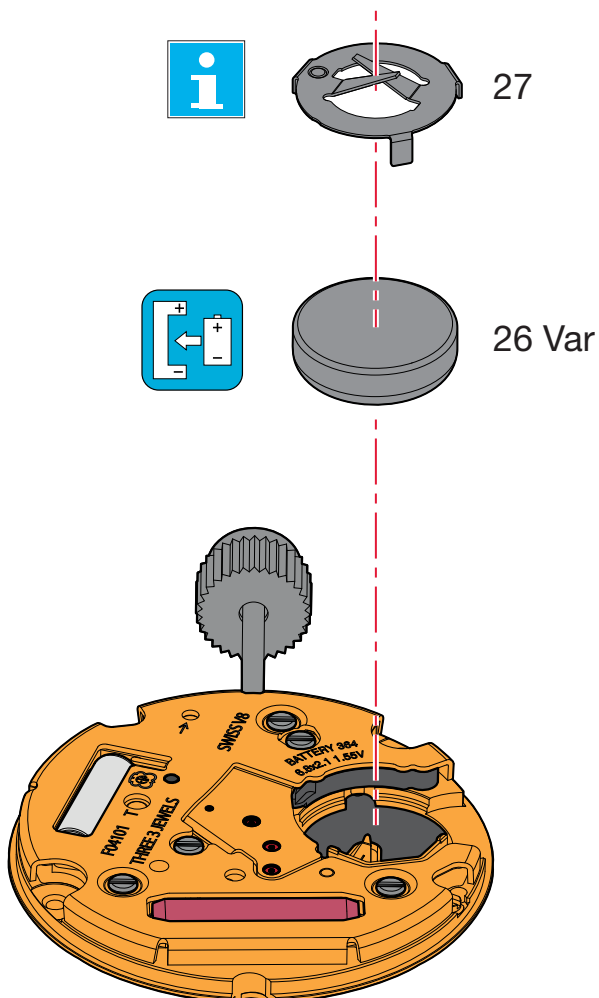

**Assembling of the battery and the battery limiting spring**

(Parts listed in order of assembly)

**Montaje de la pila para el muelle de limitación de pila**

(Lista de fornitureas por orden de ensamblado)

**Montaggio pila per la molla di limitazione della pila**

(Elenco delle forniture in ordine di montaggio)

26 Var

27

Pos 27:

The limit spring is only necessary when the distance from the battery to the base of the casing is too far.

For further details please go to:

**Manufacturing Information**  
"FRAME FOR CASE"



El muelle de sujeción solo es necesario si la distancia entre la pila y el fondo de la caja es demasiado grande.

Para más información, véase:

**Información del fabricante**  
"ARMAZÓN DE LA CAJA"

La molla distanziatrice è necessaria solo in caso di distanza ampia tra la batteria e il fondo della cassa.

Per dettagli, vedere:

**Informazioni del produttore**  
"STRUTTURA PER CASSA"

## Electrical tests - Controles eléctricos - Controlli elettrici

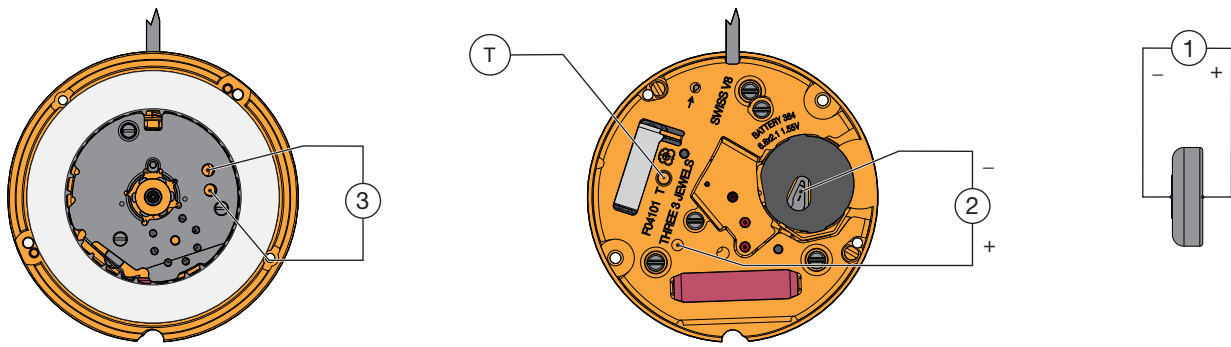

Position Posición Posizione	Setting of apparatus Escala de medición Scala di misura	Measurement Medición Misura	Test Control Controllo	Remarks Notas Osservazioni
1		1,55 V	Battery voltage Tensión de la pila Tensione della pila	
2	2 V	4 steps jump every 4 sec., when feed voltage < 1,30 V.	EOL function. Enf of life test for the battery.	Measurement without battery, with feed voltage < 1,30 V. E.O.L. function after about 2 min.
		Salto de 4 pasos cada 4 segundos, con tensión de alimentación < 1,30 V.	Función EOL. Prueba de indicación de fin de vida de la pila.	Medición sin pila, con tensión de alimentación < 1,30 V. E.O.L. funcionamiento después de ~ 2 minutos.
		Scatto di 4 passi ogni 4 secondi quando la tensione di alimentazione < 1,30 V.	Funzione EOL. Prova dell'indicazione di fine vita della pila.	Misura senza pila, con tensione di alimentazione < 1,30 V. E.O.L.-funzionamento dopo ~ 2 minuti.
	Connect T point with the – conductor. If the voltage is > 1,46 V, motor driven with 8 steps/s. If the voltage is < 1,30 V, motor driven with 32 steps/s.	Lower working-voltage limit.	Measurement without battery, with variable external power supply, starting with 1,55 V, lower tension until movement stops.	
	2 V	Conectar el punto T con la pista –. Si la tensión > 1,46 V, mando del motor a 8 pasos/s. Si la tensión < 1,30 V, mando del motor a 32 pasos/s.	Límite inferior de la tensión de funcionamiento.	Medición sin pila, con alimentación exterior variable bajando de 1,55 V hasta que la máquina se detenga.
	2 V	Mettere in contatto il punto T con la pista –. Se la tensione > 1,46 V, comanda del motore con 8 passi/s. Se la tensione < 1,30 V, comanda del motore con 32 passi/s.	Límite inferiore della tensione di funzionamento.	Misura senza pila con alimentazione esterna variabile, scendendo da 1,55 V fino all'arresto del movimento.
	10 μA	≤ 1,10 μA	Consumption of movement. Consumo de la máquina. Consumo del movimento.	Measurement without battery, with external power supply 1,55 V. Medición sin pila, con alimentación exterior de 1,55 V. Misura senza pila con alimentazione esterna di 1,55 V.
		≤ 0,5 μA	Function of stop lever, pos. 3 of handsetting stem. Funcionamiento del interruptor en pos. 3 de la tija de puesta en hora. Funzionamento dell'interruttore in posizione 3 dell'albero di messa all'ora.	Measurement without battery, with external power supply 1,55 V. Medición sin pila, con alimentación exterior 1,55 V. Misura senza pila, con alimentazione esterna di 1,55 V.



Position Posición Posizione	Setting of apparatus Escala de medición Scala di misura	Measurement Medición Misura	Test Control Controllo	Remarks Notas Osservazioni
3	1 V ( $R_i \geq 10 \text{ k}\Omega/V$ )	Hand of measuring apparatus oscillates in + and - direction.  La aguja del multímetro oscila en sentido + y -.  La lancette del multímetro oscila nel senso + e -.	Impulses at output of integrated circuit: 1 every second.  Impulsos a la salida del circuito integrado: 1 por segundo.  Impulsi all'uscita del circuito integrato: 1 per secondo.	Measurement with battery.  Medición con una pila.  Misura con una pila.
<p><i>The test must be conducted at an ambient temperature of between 20°C and 25°C. Las pruebas deben realizarse a una temperatura ambiente comprendida entre 20°C y 25°C. I test devono essere effettuati a temperatura ambiente compresa tra 20°C e 25°C.</i></p>				

**Note:**

In order to access the stops of the spool and detect the motor pulse, use two very fine points to contact the two jumper plugs as shown in point 3 of the above diagram.

**Observación:**

Para acceder a los bornes de la bobina y detectar el impulso motor, es necesario hacer contacto con las dos zonas mediante dos puntas muy finas como se indica en el punto 3 del dibujo presentado arriba.

**Osservazione:**

Per avere accesso alle bobine magnetiche e individuare l'impulso motore, le due superfici devono essere toccate con due punte finissime, come illustrato al punto 3 nel disegno di sopra.

### Fitting the battery

Slid the battery against the contact strip ①. Press the battery firmly into its mounting ②. The contact strip keeps the battery in position.

*The tweezers must not be electrically conductive!*

### Colocación de la pila

Deslice la pila hasta la brida de fijación ①. A continuación, presione la pila hacia dentro de su alojamiento ②. La brida + mantiene la pila en su posición.

*Las pinzas no deben ser conductoras de la electricidad!*

### Posa della pila

Inserire la batteria nelle staffe di contatto ①. E quindi premerla nell'apposito vano ②. La staffa + tiene la batteria in posizione.

*La pinzetta non deve condurre elettricità!*

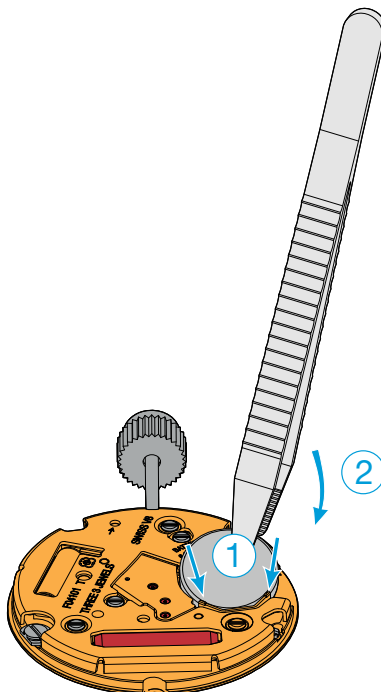

### Removing the battery

Insert tweezers ① between module and battery (see drawing) and pry out the battery by gently lifting back ② the contact strip. Remove the battery ③.

*The tweezers must not be electrically conductive!*

### Retiro de la pila

Insertar unas pinzas ① entre el módulo y la pila (véase dibujo) y palanquear la pila apartando cuidadosamente el dedo del cubre-módulo ②. Sacar la pila ③.

*Las pinzas no deben ser conductoras de la electricidad!*

### Ritiro della pila

Far scivolare una pinzetta ① tra il modulo e la pila (vedi disegno) e fare leva sotto quest'ultima allungando leggermente il dito di sostegno verso dietro ②. Ritirare la pila ③.

*La pinzetta non deve condurre elettricità!*

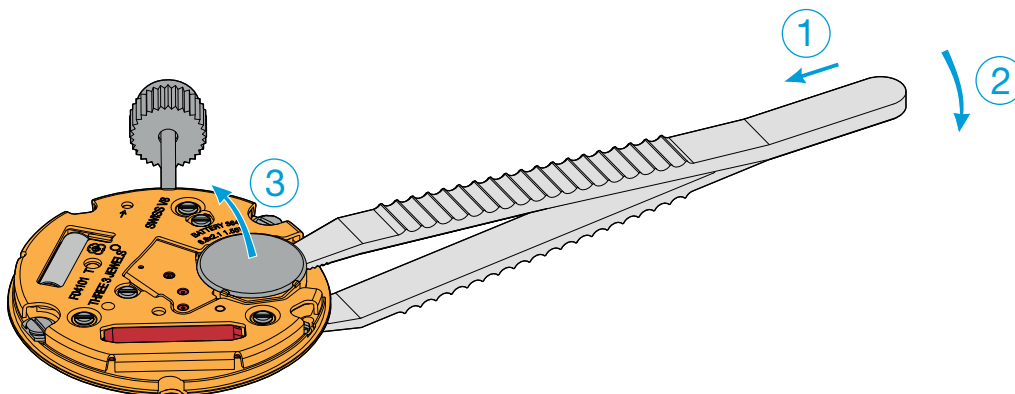

### Extracting the stem

The handsetting stem must be pushed back to position 1 (neutral) before pressing on the point lying on the right sider of the setting lever.

### Extracción de la tija de puesta en hora

Antes de pulsar el punto a la derecha del tirete, es obligatorio empujar la tija de puesta en hora en posición 1 (neutral).

### Estrazione dell'albero di messa all'ora

Prima di premere il punto a destra del tireto, è obbligatorio premere l'albero di messa all'ora in posizione 1 (neutra).

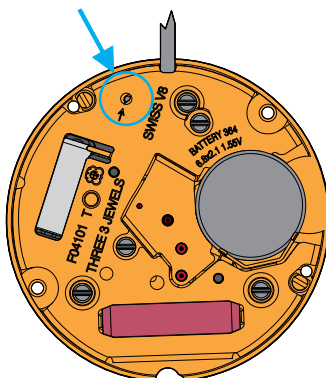

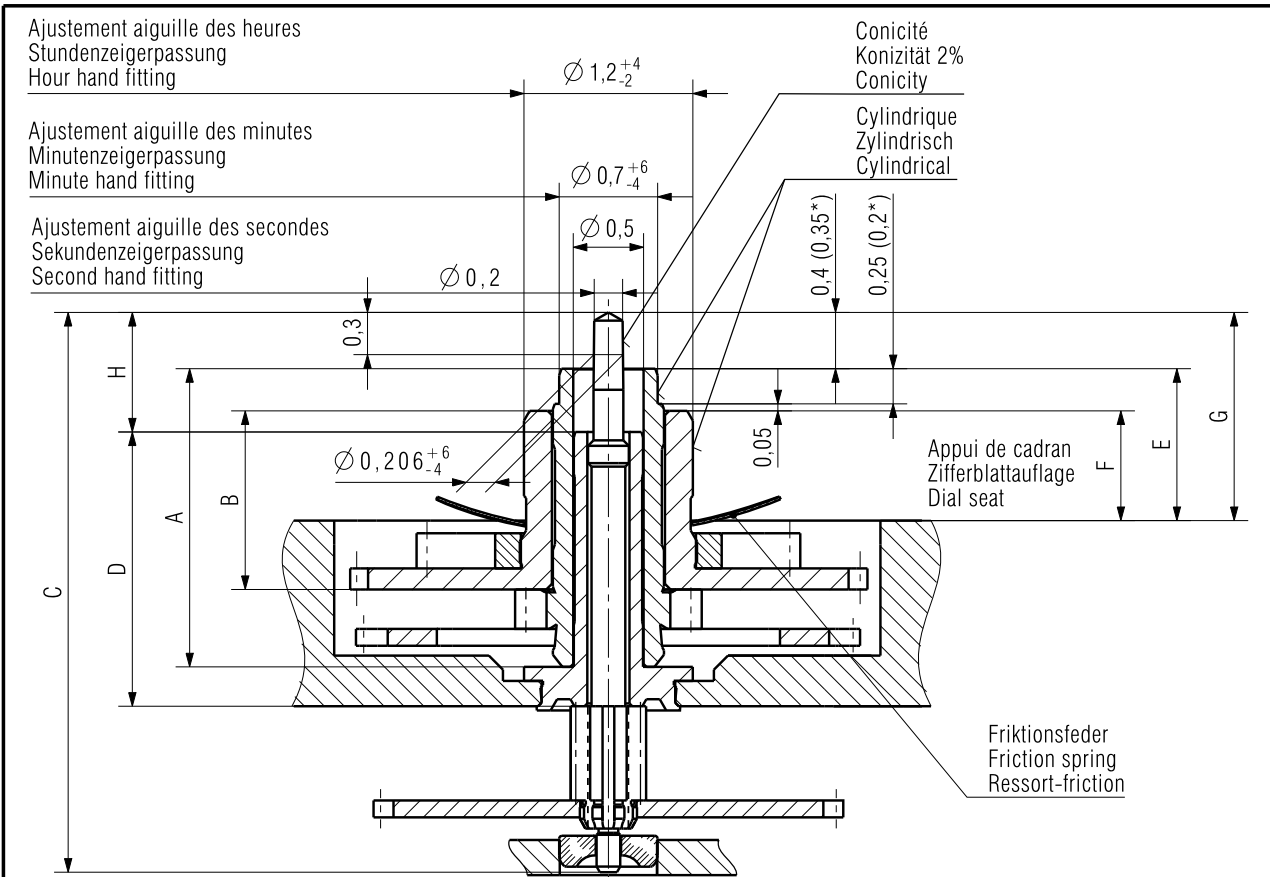

\*\* Livraison contre supplément de prix Délais sur demande  
 Lieferung gegen Aufpreis Lieferfrist auf Anfrage  
 Delivery with surcharge Delivery schedul on demand

1) NIHS 91-30: 500g / 0,7 ms      2) NIHS 91-20: 500g / 2,0 ms

Aiguillage Zeigerwerkhöhe Hand fitting height	Longueur/Länge/Length				Dépassement Höhe über Zifferblattauflage Height over dial seat			H	Ep.cadran Zifferblattdicke Dial thickness
	A	B	C	D	E	F	G		
réduit * niedrig * reduced *	1,9	1,1	3,73	1,95	0,9	0,65	1,25	0,6	0,3
1 normal	2,12	1,27	3,98	1,95	1,1	0,8	1,5	0,85	
2 **	2,37	1,52	4,23	1,95	1,35	1,05	1,75	1,1	
3 **	2,62	1,77	4,48	1,95	1,6	1,3	2	1,35	
4 **	2,87	2,02	4,73	1,95	1,85	1,55	2,25	1,6	
5 **	3,12	2,27	4,98	1,95	2,1	1,8	2,5	1,85	

Aiguilles Zeiger Hands	Aiguille d'heure Stundenzeiger Hour hand	Aiguille de minute Minutenzeiger Minute hand	Aiguille de seconde Sekundenzeiger Second hand
Masse/Masse/Mass	max. mg	30	30
Balourd/Unwucht/Unbalance	max. µNm	1) 2) 0,8	1) 2) 0,8
Force de chassage/Setzkraft/Press-in force	max. N	30	30

Kaliber / Calibre / Caliber <b>FOX.101 / 111</b> <b>FOX.401 / 411</b>	Masstab Echelle Scale --		CATIA V5
		Masse in mm Dimensions en mm Dimensions in mm	Tol.1/1000 mm

<b>AIGUILLAGES ZEIGERWERKHÖHEN HAND FITTING HEIGHTS</b>	Version <b>10</b>	Revision <b>00</b>	Blatt Feuille Sheet <b>01/01</b>
---	----------------------	-----------------------	---

 <b>ETA SA</b> MANUFACTURE HORLOGÈRE SUISSE DEPUIS 1793  A COMPANY OF THE SWATCH GROUP	Ersatz für/En remplacement de/Remplacement for	Klass. Class. <b>ZVACC</b>	<b>KUN</b>		
	Aenderung/Modification	30493	Ursprung Erzeugung Création Origine Creation Original 15.11.2001	Version Erzeugung Création Version Creation Version 07.07.2014	Freigegeben Libéré Released 07.07.2014

We reserve all rights for this document. It is meant for the recipient only and it may not be copied, printed or given to a third person without our written permission.  
 Quedan reservados todos los derechos relacionados con este documento, que está dirigido únicamente al destinatario. Queda por lo tanto prohibida su copia, impresión o cualquier otra autorización por escrito.  
 Ogni diritto su questo documento è riservato. Il documento è indirizzato esclusivamente al destinatario e non può essere copiato, stampato o ceduto a terzi senza un'autorizzazione scritta.

We reserve all rights for this document. It is meant for the recipient only and it may not be copied, printed or given to a third person without our written permission. Quedan reservados todos los derechos relacionados con este documento, que está dirigido únicamente al destinatario. Queda por lo tanto prohibida su copia, impresión a terceros sin nuestra autorización por escrito. Ogni diritto su questo documento è riservato. Il documento è indirizzato esclusivamente al destinatario e non può essere copiato, stampato o ceduto a terzi senza un'autorizzazione scritta.

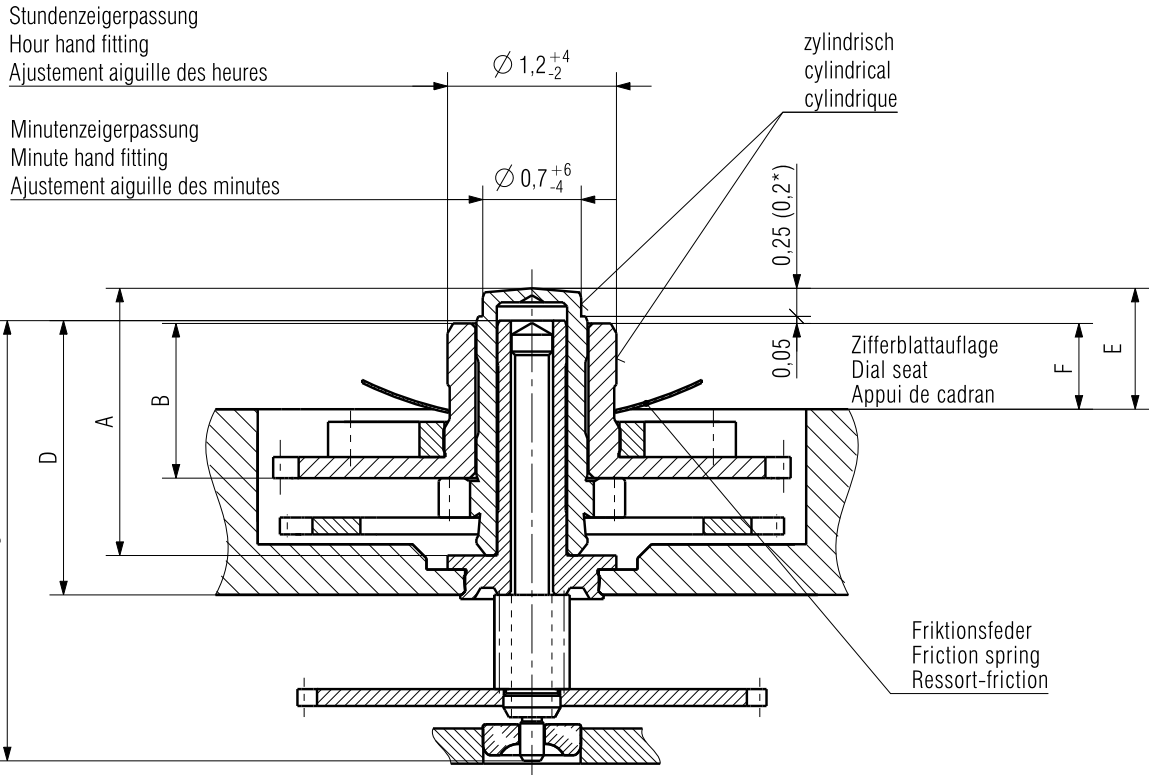

\*\* Livraison contre supplément de prix  
 Lieferung gegen Aufpreis  
 Delivery with surcharge

1) NIHS 91-30: 500g / 0,7 ms      2) NIHS 91-20: 500g / 2,0 ms

Aiguillage Zeigerwerkhöhe Hand fitting height	Longueur/Länge/Length				Dépassement Höhe über Zifferblattauflage Height over dial seat		Ep.cadran Zifferblattdicke Dial thickness
	A	B	C	D	E	F	
réduit * niedrig * reduced *	1,9	1,1	3,13	1,95	0,9	0,65	0,3
1 normal	2,12	1,27	3,13	1,95	1,1	0,8	
3 **	2,62	1,77	3,13	1,95	1,6	1,3	
Aiguilles Zeiger Hands					Aiguille d'heure Stundenzeiger Hour hand		Aiguille de minute Minutenzeiger Minute hand
Masse/Masse/Mass	max.				mg	30	30
Balourd/Unwucht/Unbalance	max.				µNm	1) 2) 0,8	1) 2) 0,8
Force de chassage/Setzkraft/Press-in force	max.				N	30	30
Kaliber / Calibre / Caliber FOX.101 / FOX.111					Massstab Echelle Scale 20 : 1		CATIA V5 Masse in mm Dimensions en mm Dimensions in mm Tol. 1/1000 mm
AIGUILLAGES ZEIGERWERKHÖHEN HAND FITTING HEIGHTS			SANS SECONDE OHNE SEKUNDE WITHOUT SECONDS			Z0048998	Version 07 00 01/01
<b>ETA SA</b> MANUFACTURE HORLOGÈRE SUISSE DEPUIS 1793			Ersatz für/En remplacement de/Remplacement for Aenderung/Modification			Klass. ZVACC	Blatt Feuille Sheet KUN
A COMPANY OF THE <b>SWATCH GROUP</b>			30493			Ursprung Erzeugung Création Origine Creation Original 04.01.2002 ZWJ	Version Erzeugung Création Version Creation Version 07.07.2014 KLO
						Freigegeben Libéré Released 07.07.2014 WIR	

This page has deliberately been left blank in case of A3 format printing.

Esta página se han dejado en blanco a propósito en caso de imprimirla en formato A3.

Questa pagina è lasciata intenzionalmente bianca in caso di stampa formato A3.

This page has deliberately been left blank in case of A3 format printing.

Esta página se han dejado en blanco a propósito en caso de imprimirla en formato A3.

Questa pagina è lasciata intenzionalmente bianca in caso di stampa formato A3.

**Modifications compared with previous document versions****Modificaciones comparadas con las versiones anteriores del documento****Modifiche comparate con le versioni precedenti del documento**

Version Versión Version	Date Fecha Data	Modification	Modificación	Modifica	Page Página Pagina
03	06.08.2014	New drawings	Nuevos planos	Nuovi disegni	20-21
02	26.06.2014	New drawing	Nuevo plan	Nuovo disegno	20
		Adaptation variant and GTIN number	Adaptación variante y número GTIN	Adattamento variante e numero GTIN	3-6, 10
01	04.09.2013	Basic version	Versión de base	Versione di base	--
00	06.09.2013	Intern error / invalid version	Error interno / versión inválida	Errore interno / versione non valida	--

All modifications reserved.

Salvo modificación.

Con riserva di ogni eventuale modifica.

**This document can be found on the Support Center Portal (SCP):****www.eta.ch**

- Support Center
- Support Center Portal
- Technical Documents

**Este documento se encuentran en el Support Center Portal (SCP):****www.eta.ch**

- Support Center
- Support Center Portal
- Technical Documents

**Il presente documento si trovano sul Support Center Portal (SCP):****www.eta.ch**

- Support Center
- Support Center Portal
- Technical Documents



**ETA**<sup>SA</sup>  
MANUFACTURE HORLOGÈRE SUISSE  
DEPUIS 1793

SC PRODUCT COMMUNICATION

Bahnhofstrasse 9  
2540 Grenchen  
Switzerland

Phone +41 (0)32 655 71 11  
Fax +41 (0)32 655 71 74

contact@eta.ch  
www.eta.ch